

LISTA DE MATERIALES KIT ANTIEMPOTRAMIENTO LATERAL A CARROCERÍA		CANT. POR KIT
1	SOPORTE ARTICULADO ANTICICLISTA CINCADO HOMOLOGADO	4
2	CANTONERA ANTIEMPOTRAMIENTO L=500	2
3	RECTANGULAR ANTIEMPOTRAMIENTO L=3500 / 4500	4
4	TAPE PERFIL RECTANGULAR ANTIEMPOTRAMIENTO DE CICLISTAS	4
5	TAPE DE CANTONERA	2
6	TORNILLO HEXAGONAL DIN 933 8.8 M8 X 30 CINCADO	8
7	ARANDELA PLANA DIN 125 Ø8 CINCADA	8
8	ARANDELA ESTRIADA DIN 6798 Ø8 CINCADA	8
9	PLETINA 30 X 30 X 5 CINCADA ANTICICLISTA ROSCADA M8	8
10	REMACHE ACERO Ø6,4x15	8
11	PEGATINA HOMOLOGACIÓN	10

COLOCAR A CARROCERÍA CON 8 TORNILLOS HEXAGONALES 8.8 M12



INSTRUCCIONES DE MONTAJE PARA  
DISPOSITIVO DE PROTECCIÓN LATERAL  
A CARROCERÍA

Nº: R07301003

Diciembre 2021

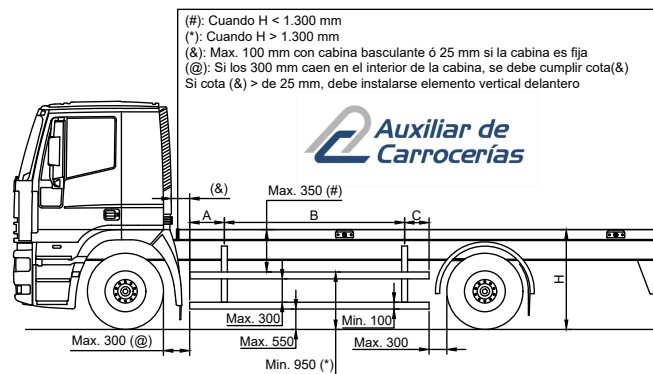
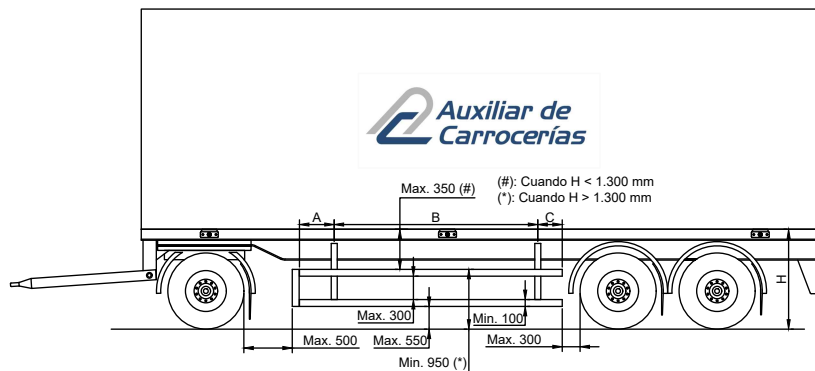
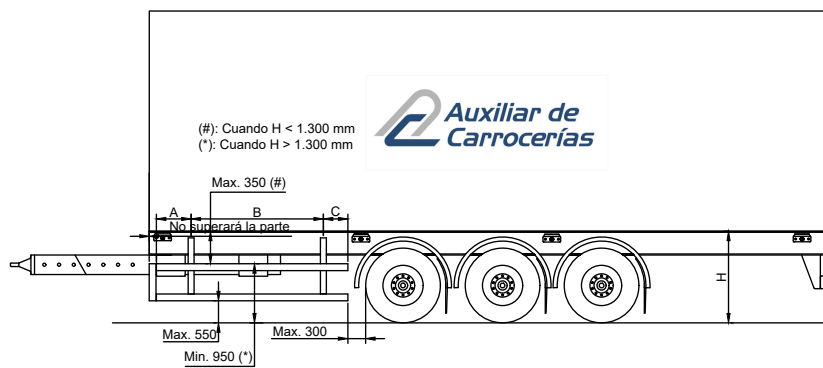
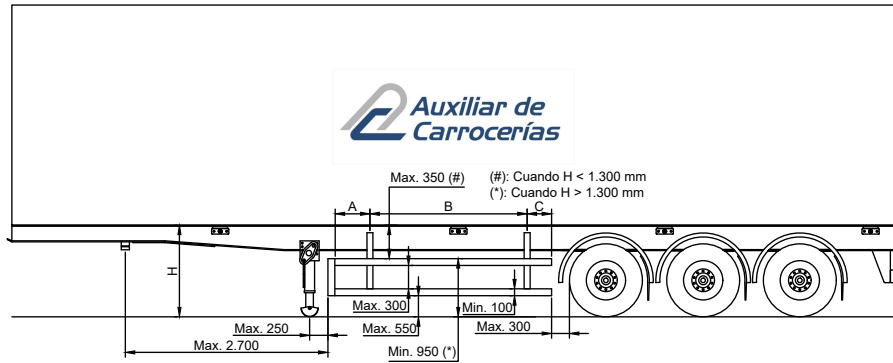

	Dim. Máx. (mm)		
	A	B	C
TAC-PL-CARROCERIA	900	3.350	250
TAC-PL-CHASIS	875	3.300	150

